



MOBILE APP SEARCH

 iPhone ▼ 

Cathy Edwards
CTO and co-founder

- Undergraduate degrees in Pure Mathematics, Computer Science, Linguistics from University of Western Australia
- Machine learning at the Telstra Research Laboratories (with the team who won the KDD Cup in 2002)
- Technical product management both within Telstra and in mobile startups
- Co-founder and CTO at Chomp

1. Why are apps important?
2. App search: challenges
3. Our solution
4. Results
5. Future work

Apple iPhone + iTouch + iPad Ramp – The Likes of Which We Haven't Seen Before

iPhone + iTouch vs. NTT docomo i-mode vs. AOL vs. Netscape Users
First 20 Quarters Since Launch



Morgan Stanley

Note: *AOL subscribers data not available before CQ3:94; Netscape users limited to US only. Morgan Stanley Research estimates ~65MM+ netbooks have shipped in first 11 quarters since launch (10/07). Source: Company Reports, Morgan Stanley Research. Data as of CQ3:10.

~1M mobile apps (across iPhone, iPad, Android)

More apps than there were websites in 1996

Growing faster than websites were in 1996

Estimated 44B app downloads by 2016

Remember when you used to find webpages by **browsing?**



Google had a directory on their homepage as late as **2001**

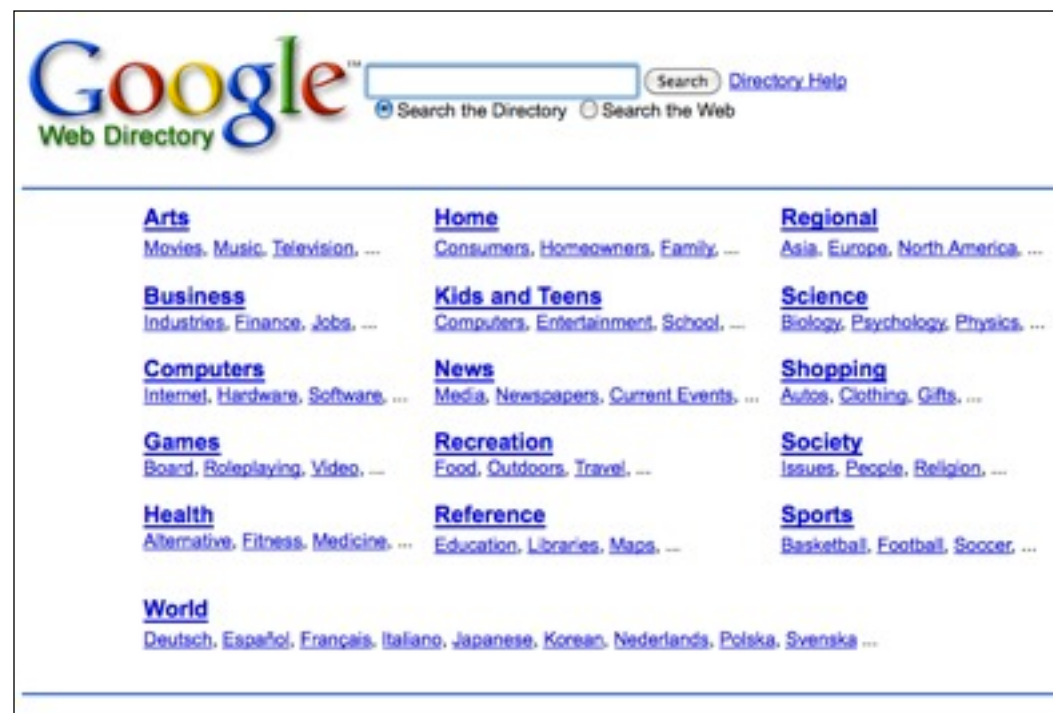

There's an app for
that?!?!

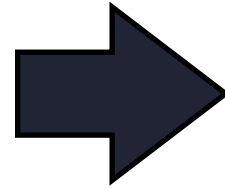

Of course there's an
app for that!

What apps exist?

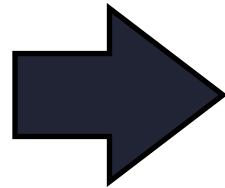

How do I find what I
want in the clutter?

Browse

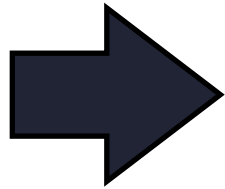

Search

The answer is **search**

What's so hard about that?

Fundamentally different **user expectations**

www.facebook.com **tsunami**
facebook login **tmz**
mission est binding snowboard boot size



free photography **rpg**
wallpapers **discounts**
puzzle games **chat**



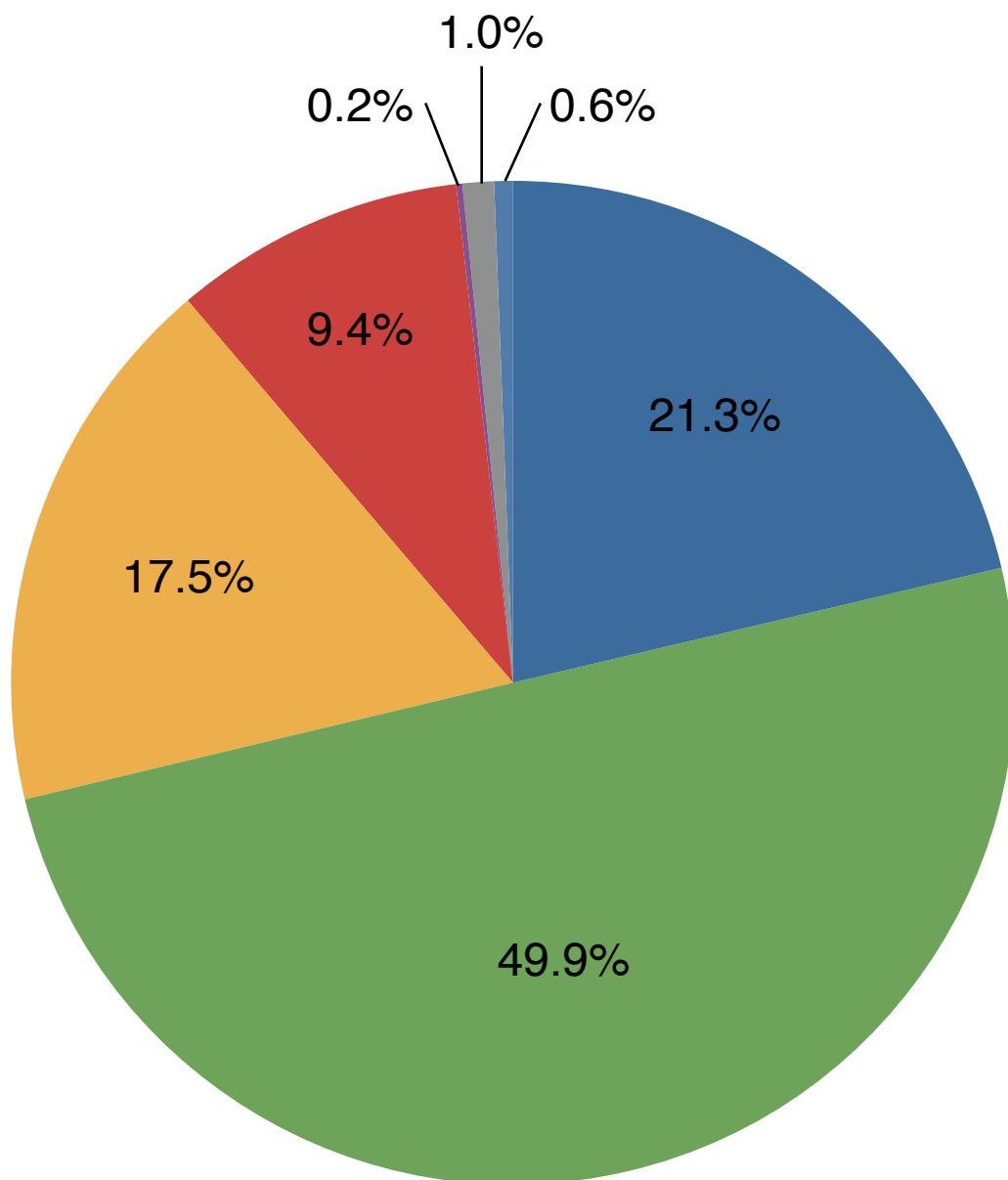

- navigational e.g. [Angry Birds]
- functional e.g. [to do list]
- category name e.g. [music]
- browse e.g. [top apps]
- developer name e.g. [Zynga]
- user group e.g. [kids games]
- location e.g. [sfo]

Average web search query = **3 words**
Average app search query = **1.5 words**

typing sucks on mobile...

Document = app description+name(+other stuff)

- 1.** Very short
- 2.** Not written with SEO in mind
- 3.** Document language != Query language



\$0.99 Buy App

Camera+

Description

It's all about one thing... GREAT PHOTOS!

Whether you're a seasoned photographer or someone who's barely touched a camera, Camera+ will make you love taking photos.

Everybody has a creative side... Camera+ will help bring that creativity out in you, all with a fun, innovative, and beautiful design.

★ EXCLUSIVE Touch Exposure & Focus for the ultimate control...

Set exposure separately from focus for the ultimate control of your shots... simply touch with a 2nd finger while focusing to adjust exposure until your shot is perfect. [available on iPhone 4 and 3GS on iOS4 only]

★ EXCLUSIVE Photo Flashlight to brighten up your photos.

Use the iPhone 4 LED flash as a continuous fill light to improve photo quality, especially for portrait and macro shots.

★ No more blurry shots...

Use the stabilizer to steady your camera and get the sharpest pics you can.

★ Put an end to crooked pics...

Use the grid to line up your shots and eliminate unsightly angled photos.

★ Highest quality zoom...

Camera+ has a 6x digital zoom that simply blows away the competition in terms of quality.

★ Scene modes and flash...

Most modern digital cameras all have scene modes to help you get the best photos for your particular situation. And why shouldn't your iPhone have this great feature? Well, with Camera+, you get to choose from several scene modes including Backlit, Sunset, Night, Portrait, Beach, and many more. And for the times when your photos came out too dark, we have a high quality digital flash to make them look great.

★ Crops let you frame your pics perfectly...

If you didn't line up your shot perfectly when you took it, you can easily fix that with Camera+. And when you want to get a bit creative, we setup a bunch of popular crop sizes for you. With a single tap, you can make your pics square, 4x6, 8x10, etc.

“editing” = 0

“edit” = 0

“photo” = 1

“photos” = 3

photo editor

About 80,100,000 results (0.12 seconds)

edit all your photos

[Picnik](#)
www.picnik.com/
Picnik lets you **edit** all your **photos** online, from one easy place.
Basic Uploader - Make your own show - Flickr - Tools
1,860 people +1'd this

Photo editor
pixlr.com/editor/

[Photo editor online / free image editing direct in your browser - Pixlr ...](#)
pixlr.com/editor/
Pixlr Editor is a free online **photo editor** with a professional touch. Fix, adjust and filter your images. Manage your images in your browser, no registration ...

photo editor

[LunaPic | Free Online Photo Editor](#)
www.lunapic.com/
load Free Online **Photo Editor**. Photo, liquid and paint effects. Great for Tumblr, Myspace, Facebook or Twitter. Lunapics Image software free image ...
Top Rated Effects - Skin Tanning - Webcam Capture - Paint Bucket Tool

Photo Editor

Photo Editor.

[FotoFlexer - The world's most advanced online photo editor](#)
fotoflexer.com/
FotoFlexer is the most powerful online **photo editor** in existence. It can remove blemishes, change skin/hair color, morph photos and more! 100% free.
Get Started Now - Login - Photo Editing Demos - Terms of Service

photo editor

photo editor

PHOTO EDITOR

[ONLINE PHOTO EDITOR - Edit your photos, pictures and images ...](#)
www.freeonlinephotoeditor.com/
Edit your photos online on Free Online **Photo Editor**.com: resize, filters, sepia, crop, rotate and flip, online **photo editing**, **photo editing**, photo tool, image editor, ...

Photo Editor.com

www.freeonlinephotoeditor.com/

photo editing, photo editing,

Recall is a big problem

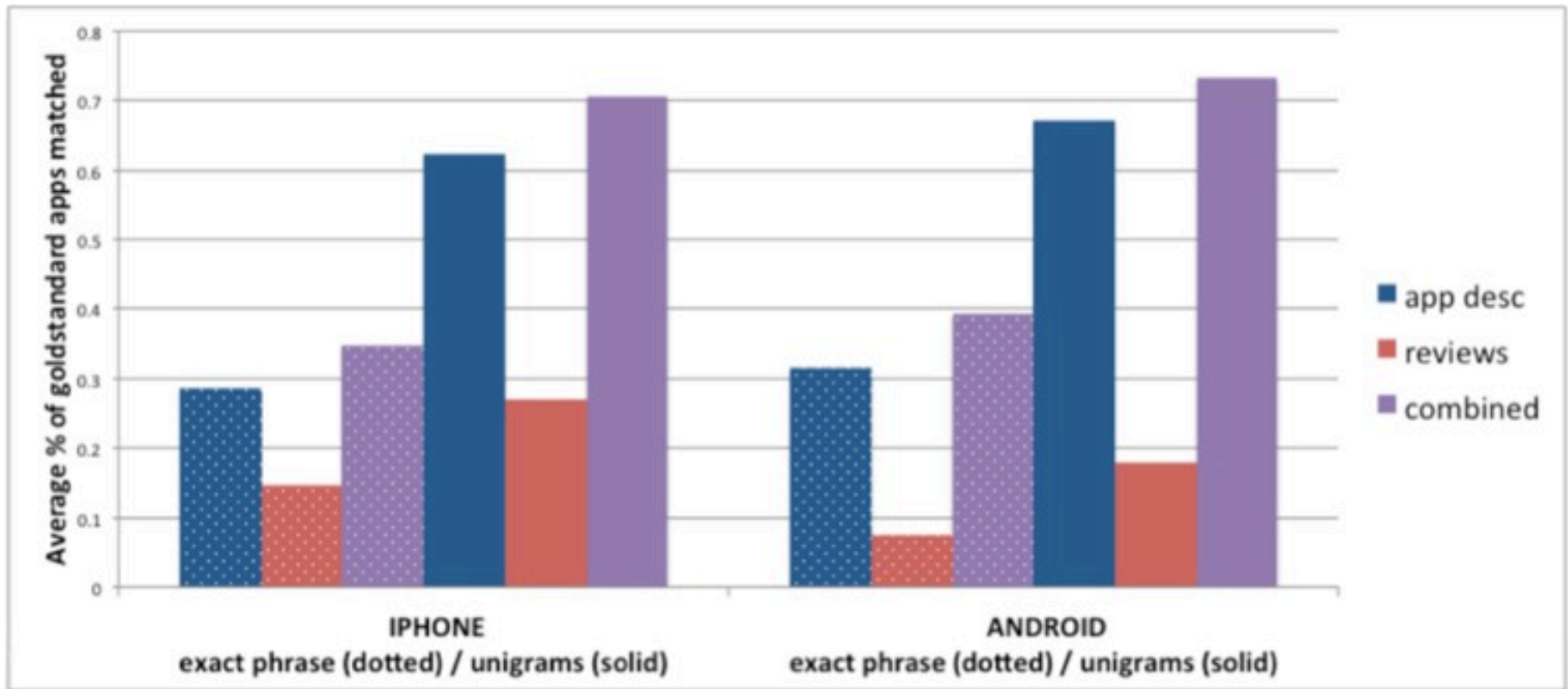

TFIDF **doesn't work**

Ontologies don't scale

Apps don't have a link structure:
no **PageRank** or **anchor text**

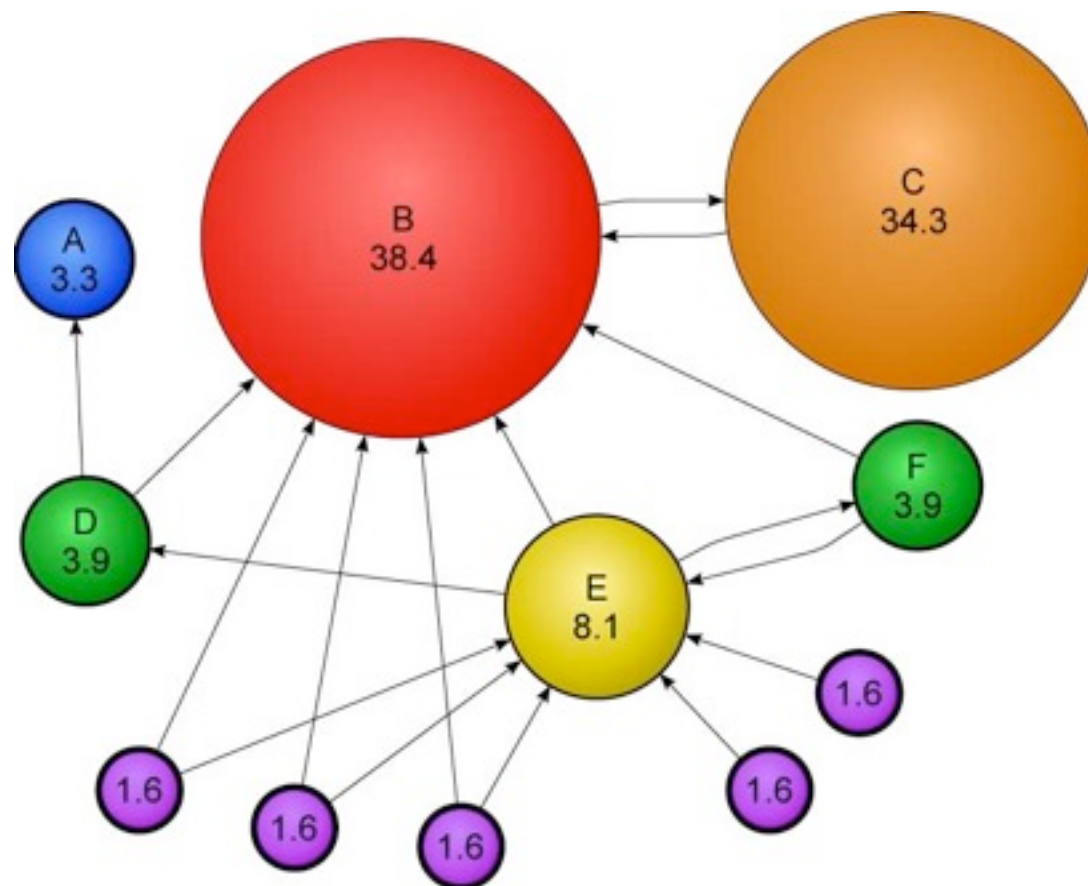

How do we solve this?

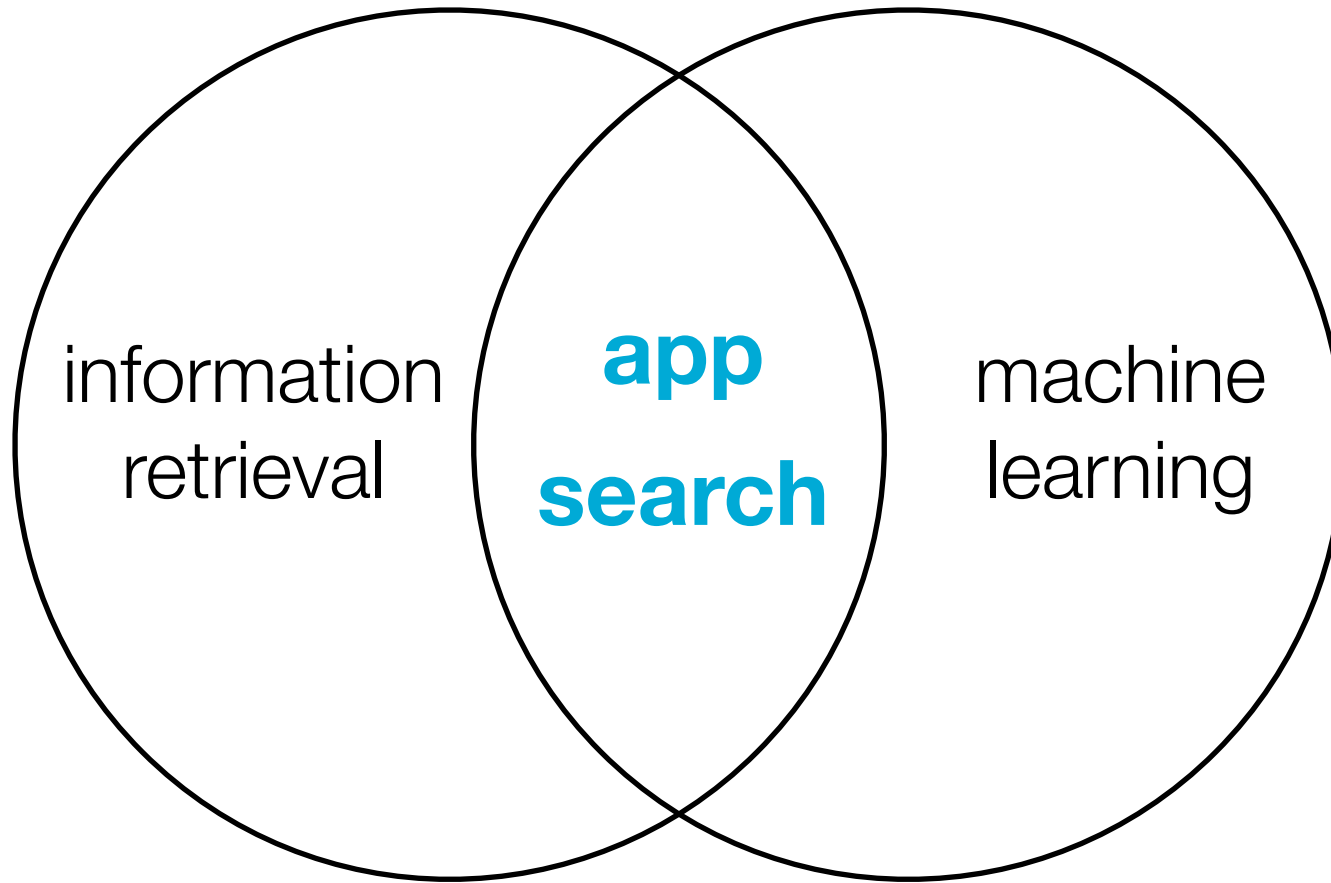



\$0.99 Buy App

Camera+

Description

It's all about one thing... GREAT PHOTOS!

Whether you're a seasoned photographer or someone who's barely touched a camera, Camera+ will make you love taking photos.

Everybody has a creative side... Camera+ will help bring that creativity out in you, all with a fun, innovative, and beautiful design.

★ EXCLUSIVE Touch Exposure & Focus for the ultimate control...

Set exposure separately from focus for the ultimate control of your shots... simply touch with a 2nd finger while focusing to adjust exposure until your shot is perfect. [available on iPhone 4 and 3GS on iOS4 only]

★ EXCLUSIVE Photo Flashlight to brighten up your photos...

Use the iPhone 4 LED flash as a continuous fill light to improve photo quality, especially for portrait and macro shots.

★ No more blurry shots...

Use the stabilizer to steady your camera and get the sharpest pics you can.

★ Put an end to crooked pics...

Use the grid to line up your shots and eliminate unsightly angled photos.

★ Highest quality zoom

Camera+ has a 6x digital zoom that simply blows away the competition in terms of quality.

★ Scene modes and flash...

Most modern digital cameras all have scene modes to help you get the best photos for your particular situation. And why shouldn't your iPhone have this great feature? Well, with Camera+, you get to choose from several scene modes including Backlit, Sunset, Night, Portrait, Beach, and many more. And for the times when your photos came out too dark, we have a high quality digital flash to make them look great.

★ Crops let you frame your pics perfectly...

If you didn't line up your shot perfectly when you took it, you can easily fix that with Camera+. And when you want to get a bit creative, we setup a bunch of popular crop sizes for you. With a single tap, you can make your pics square, 4x6, 8x10, etc.

Topic modeling can help capture this

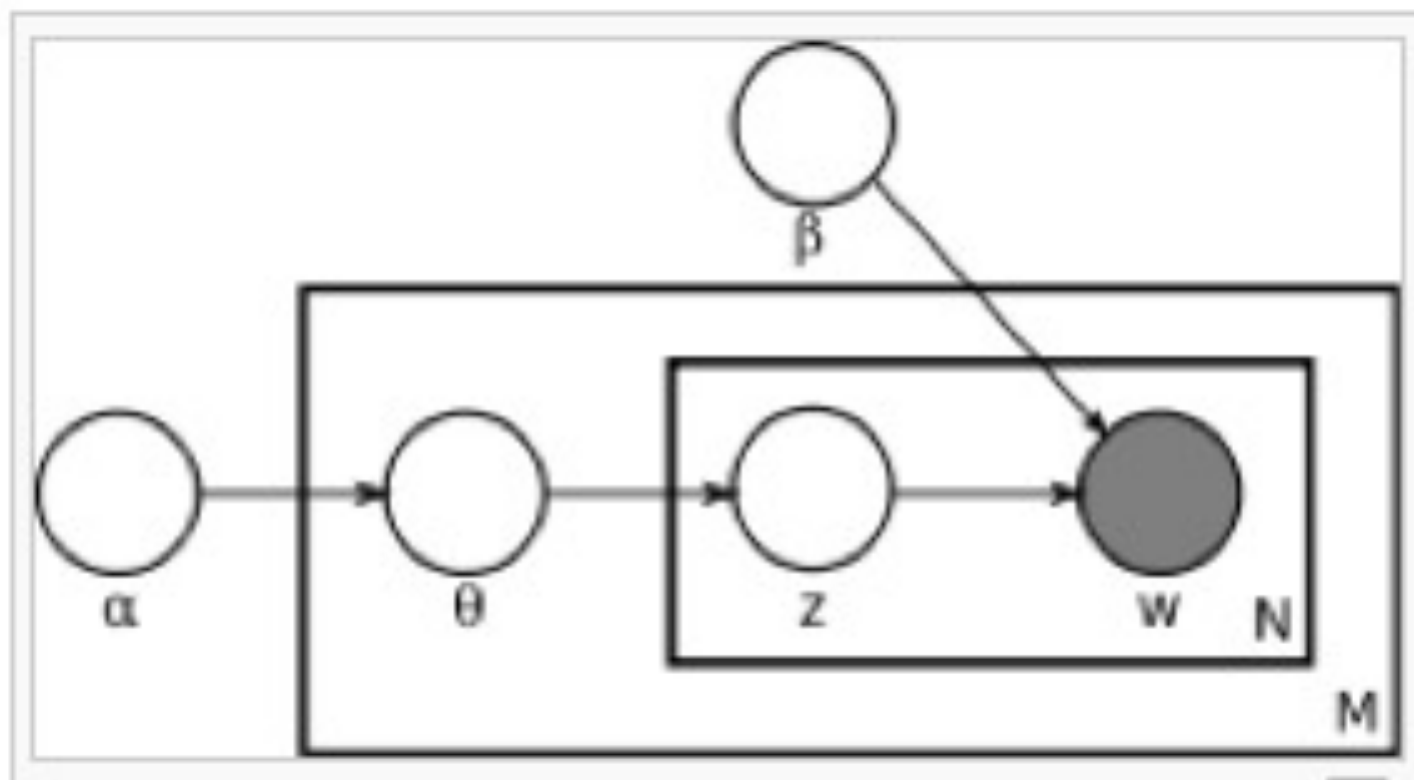

Blei, D., Ng, A. & Jordan, M,
Latent Dirichlet Allocation. In
*Journal of Machine Learning
Research*, 3, 993-1022, 2003

Chomp learns **app function**

voice
speech
speak
phone
recognition
command

map
marker
satellite
earth
street
pin

sleep
noise
white
frequency
relax
ambient



voice: 90%
recognition: 82%
maps: 86%
street: 43%
command: 53%

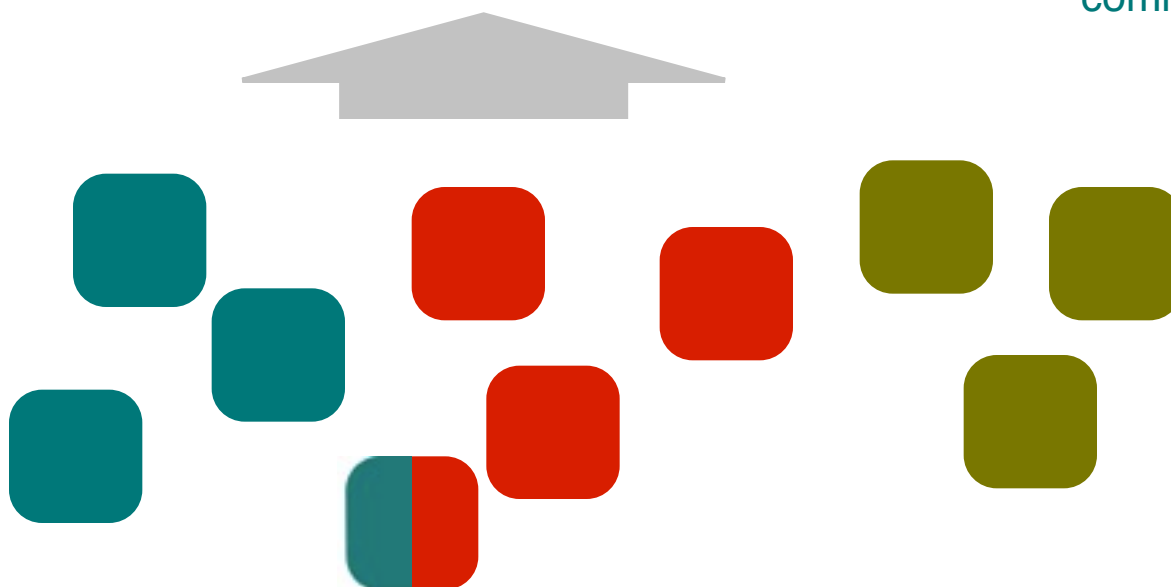

Does this help?

LDA feature is not a replacement for LDA; however
there are interesting **interaction effects**

Random Forest (L2 norm):

TFIDF - 0.560
LDA - 0.566
combined - 0.617

NB: preliminary results only

Where does this go?

Over the next couple of years, search will increasingly dominate app discovery on mobile

(and thus, search advertising will be increasingly important for developers)

We haven't fully solved the query/document language problem: e.g. [maps] -> strategy games

Supervision?

Don't constrain the number of topics (Chinese Restaurant Process)?

Somehow cluster queries?

Questions?

CONTACT INFORMATION

Cathy Edwards
CTO & Co-Founder
cathy@chomp.com
@cathye